



## LESSON SNAPSHOT

### **BOTTOM LINE:**

God has a special plan for each of us.

### **BIBLE STORY:**

Exodus 12:1-14, 31-42, Passover

### **SUMMARY:**

There's usually nothing very extraordinary about your average drive-thru meal; you're usually just there to get a simple meal and get back on the road. The Israelites journey out of slavery began with a very simple, but special meal to show us that God has special things in store for us.

### **SIMPLE PRAYER:**

*Dear God,*

*Thank you for the plans you have for us!*

*In Jesus' name,  
Amen*

# SUMMER ROAD TRIP



## SKIT

### VACATION PICS: THE DRIVE THRU

#### ITEMS NEEDED:

A cell phone

#### CHARACTER BREAKDOWN:

1M, 1F

#### CHARACTERS:

Kirsty- An excited girl home from vacation

Dave- Kristy's friend

*Kirsty enters from stage left. Dave enters from stage right.*

KIRSTY: Hey Dave! How are you? I haven't seen you in ages!

DAVE: It's been two weeks since school let out.

KIRSTY: Has it only been two weeks? It seems so much longer! That's because I've been on vacation!

DAVE: Cool.

KIRSTY: You bet it was cool! I took a road trip with my family, we saw so many amazing things. Hey, you wanna see my pictures?

DAVE: Well, I—

KIRSTY: Sure you do! (pulls her phone out)

DAVE: Well, I am kind of in a—

KIRSTY: Look! Here's us loading the car! Here's dad, loading our suitcases. Here we are, pulling out of the driveway. Here we are getting on the Interstate. Here we are, pulling back in at the house.

DAVE: That was a short trip.

# SKIT

KIRSTY: We had to go back. Dad forgot our Mom.

DAVE: Oh.

KIRSTY: Here we are back on the road. Here's my brother Jake saying he's hungry. Here we are making hungry faces. Here's my Dad.

DAVE: Why is his face red?

KIRSTY: He just got done yelling, "WE JUST GOT ON THE ROAD! HOW CAN YOU BE HUNGRY?"

DAVE: He looks really mad.

KIRSTY: He was, but he finally pulled over and got us lunch. Look! Here we are at Arby's. Here we are at the drive-thru menu. And here we are getting our food. There's the nice lady who took our order. Isn't she pretty?

DAVE: Did you really take all these pictures of lunch?

KIRSTY: Of course I did!

DAVE: But its just lunch! It's no big deal.

KIRSTY: You know Dave, sometimes a small meal can mean a lot. This meal reminded us that Dad loved us. And it made me think of another light meal - the Passover meal.

DAVE: What's that?

KIRSTY: It's the meal the Israelites shared the night before they left Egypt. God wanted them to be ready to leave, just like my Dad the morning we left on vacation. He told them what to prepare for dinner and how to do it. It was a simple meal the Jews still celebrate today to remind them of God's plans for them.

DAVE: Wow. Must have been a special meal.

KIRSTY: It was a special meal to help them remember a special plan.

DAVE: God must have loved them a lot.

KIRSTY: And he loves us a lot too.

DAVE: You're kidding!

# SKIT

KIRSTY: Nope!

DAVE: Do you think he has a special plan for me?

KIRSTY: Of course he does!

DAVE: Then why doesn't he tell me like he told the Israelites?

KIRSTY: Well, he just used me to tell you, didn't he?

DAVE: Mind blown!

KIRSTY: Believe me, buddy, God has a plan for you. Something exciting that you can't even imagine. Remember that the next time you eat Arby's.

DAVE: I will! I will!

*Kirsty exits.*

DAVE: But I don't like Arby's!



## OBJECT LESSON OR KIDS SERMON

### ITEMS NEEDED:

A Happy Meal

How many of you have a Happy Meal at least once a month? How many of you have them more than once a month? How many of you have never, ever had a Happy Meal?

Happy Meals are the king of fast food kids meals. Today's Happy Meals come with a burger or chicken nuggets, a couple sides like apples, yogurt, or fries, and a drink. But let's be honest. There's one reason kids want the Happy Meal, and what is that reason?

It's the toy!

This simple meal comes with a cool toy, a special treat that makes these meals memorable. If we are mindful, this simple meal with this special toy can remind us of another meal: the Passover. Passover is the meal God's people celebrated right before God set them free from slavery. They left Egypt and traveled to the land of their forefathers to fulfill the amazing plans God had for them.

When you sit down with your next kids meal, whether it's from McDonalds or some place else, take a moment to thank God for your food and the awesome plans he has for you. Trust God, and he will show you those plans in his own time.

## LARGE GROUP GAME

### FRENCH FRY DROP

#### ITEMS NEEDED:

Two small cups

Two medium orders of fries (or stick pretzels are an easy alternative that may be easier to obtain)

#### INSTRUCTIONS:

Choose two players for this game. Give each player a pack of French fries, and set a cup in front of each of them. The players will have 30 seconds to drop as many fries as they can, one at a time, into the cup. The player who gets the most fries into their cup wins.

#### VARIATION:

Instead of a timed contest, make it a race to see who can get 10 fries into their cup first.

#### WHAT'S THE POINT?

Passover was a simple meal, like a drive-thru meal, intended to remind God's people of his plans for them.



## LARGE GROUP LESSON

### **BOTTOM LINE:**

God has a special plan for each of us.

### **BIBLE STORY:**

Exodus 12:1-14, 31-42, Passover

### **INTRO:**

Who is planning on taking a road trip vacation this summer? Who has already taken a fun road trip this year? Summer is the time when many families pack up the car and hit the road. They travel to the beach, to the city, to Gatlinburg, to Disney World, and all points in between. They set out to see new things, to do new things, and to spend some quality time together.

Some people prefer to get where they are going faster by taking a plane, but when you fly on vacation, you miss out on things that an airline just can't give you. You don't get to read the billboards on the Interstate. You don't get to see deer on the side of the road. You don't get to catch the crazy tourist traps America has to offer. And you never get to hear anyone say, "Dad! I need to go to the bathroom!"

Today we're going to begin a summer road trip of our own. We're hitting the road and following the path of one of the most famous road trips in the Bible: the journey of God's people Israel from slavery in Egypt, to their new home in the Promised Land. You may experience some long and wild road trips in your lifetime, but believe me, none will compare to the journey we're about to follow.

The road trip begins in the country of Egypt, where God's people have been living as slaves for generations. The Egyptians have been cruel masters, forcing the Israelites to work hard with little pay and little rest. After many years of hearing his people cry for help, God chose a man named Moses to lead Israel out of Egypt to a land he had prepared for them. On the night before they left town, the Israelites packed their bags and shared something that every family shares on a road trip: a quick and simple meal they called the Passover.

**READ EXODUS 12:1-14**



# LARGE GROUP LESSON

## **MAIN POINT:**

When you're on a road trip, trying to get from your home to your vacation destination, there's not a lot of time to sit down and eat. Most of the time you're taking a potty break and getting dinner to go. Or if Dad gets his way, you're going through the drive thru!

That's exactly the kind of meal God had in mind for his people. He knew that once his plan to let Israel go went into effect, Pharaoh would tell the Israelites to leave town immediately.

## **READ EXODUS 12:31-42**

There was no time to sit down, no time to make a fancy meal. The Israelites had their meal to go, and they left town!

To this day, the Jewish people still celebrate Passover. They do it to remember what God did for them when he saved them from slavery. The Passover meal is a reminder not only of that plan, but of the plans God has for each of us. God wants us all to follow him, like the Israelites did out of Egypt, because God has an amazing plan for each of us.

## **DRIVE IT HOME:**

Many times people will look back on their vacations and remember some special meals. Southern folks may remember one time when they got to try real Chicago pizza for the first time, and Northerners may remember the time they tried Sonic down south. They may remember a meal that took place near one of their favorite monuments. Or they may remember a meal for other reasons - like the time your brother got sick and threw up in the car after eating too many Taco Bell tacos!

Even the simplest of meals can become memorable occasions. A special meal out with a parent. A time when your parents took you to Chick-Fil-A with your cousins to play on the playground. A time when your Mom and Dad took you to McDonalds after a big game or a big test.

The simple meal we call Passover is a reminder of God's amazing plans. It not only reminds us that God saved Israel from slavery in Egypt, the blood of the lamb reminds us of what Jesus would do for us on the cross. Jesus was the perfect lamb who died for our sins! God wants each of us to believe Jesus is our Savior, and when we do, he has a plan for your life only he can fulfill.

Maybe God has a plan for you to be an artist or a musician. Maybe his plan for you is to create a new ministry to help the needy, here or in another country. Maybe he wants you to go into the ministry.

# LARGE GROUP LESSON

Or maybe he wants you to minister by being a godly man or woman. Whatever God's plan may be, it is yours alone to follow.

The next time you sit down to a simple meal, thank God for the food he's given you. Then thank God for the plans he has for you. Ask God to show you his plans, and ask him to lead you, like the Israelites. God will show you the way, and he will amaze you with the plans he has in store.

## **CLOSE WITH A SIMPLE PRAYER:**

*Dear God,*

*Thank you for the plans you have for us!*

*In Jesus' name,  
Amen*



## SMALL GROUP DISCUSSION (K-2ND)

### ICEBREAKER:

What's your favorite drive thru restaurant?

### SMALL GROUP GAME/ACTIVITY:

Play a game of fast food charades. Write the names of some favorite fast food restaurants on cards, have each kid draw a card, and then give each kid a turn to see if the others can guess the restaurant they drew.

### DISCUSSION QUESTIONS:

**Read Exodus 12:1-14, 31-42**

What meal did God give the Israelites before they left Egypt?

What were God's instructions for the meal?

What did Pharaoh tell Moses and Aaron to do?

Do you believe that God has a plan for you like he did the Israelites?

How can we find God's plan for our lives?

### SIMPLE PRAYER:

*Dear God,*

*Show us your plans and we will follow.*

*In Jesus' name,*

*Amen*



## SMALL GROUP DISCUSSION (3-5TH)

### ICEBREAKER:

What's your favorite drive thru restaurant?

### SMALL GROUP GAME/ACTIVITY:

Play a game of fast food charades. Write the names of some favorite fast food restaurants on cards, have each kid draw a card, and then give each kid a turn to see if the others can guess the restaurant they drew.

### DISCUSSION QUESTIONS:

**Read Exodus 12:1-14, 31-42**

What were God's instructions for the Passover?

What did the people do when Pharaoh told them to leave?

How does the Passover meal remind us of what Jesus did?

How do we know God has plans for our lives today?

What can we do to find God's plan for our lives?

### SIMPLE PRAYER:

*Dear God,*

*Show us your plans and we will follow.*

*In Jesus' name,*

*Amen*

# SUMMER ROAD TRIP



# MAKE IT STICK

5 Simple Ways You Can Make This Lesson Stick With your Kids

## Summer Road Trip 1

### THIS WEEK'S LESSON: DRIVE-THRU



#### IN THE CAR:

Ask your child what they learned about today on the drive home:

There's usually nothing very extraordinary about your average drive-thru meal; you're usually just there to get a simple meal and get back on the road. The Israelites journey out of slavery began with a very simple, but special meal to show us that God has special things in store for us. Exodus 12:1-14, 31-42, Passover



#### HANGING OUT:

Make today's lesson real:

Take the kids out for a take out or drive thru meal. Share with them a memorable meal you had with your parents and why it meant something to you. Ask your kids how simple things like the Passover meal can remind us of God's plans.



#### AT DINNER:

Here are some great discussion starters:

- What is the Passover meal?
- How did the Passover remind God's people of how he saved them?
- How do we know that God has great things in store for us?



#### PARENT TIME:

What you need to know:

The Passover not only foreshadowed the future of Israel and their escape to the Promised Land, it pointed to the coming of Jesus and our Salvation. God has great things in store for us if we believe Jesus is our Savior and choose to follow Him with our whole lives. Remind your kids of this promise, and pray with them that God will lead all of you just as he did Moses and the Israelites.

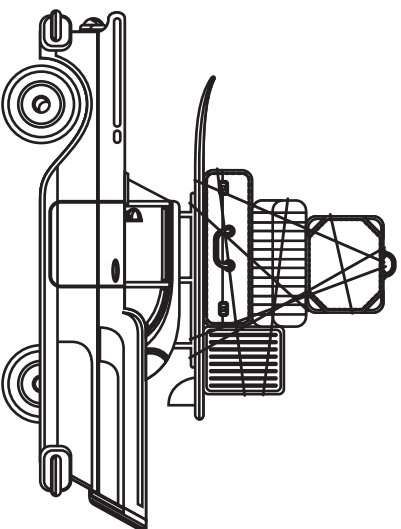

"Into your hands I commit my very life. Lord, set me  
free. You are my faithful God."  
- Psalm 31:5 (NIRV)

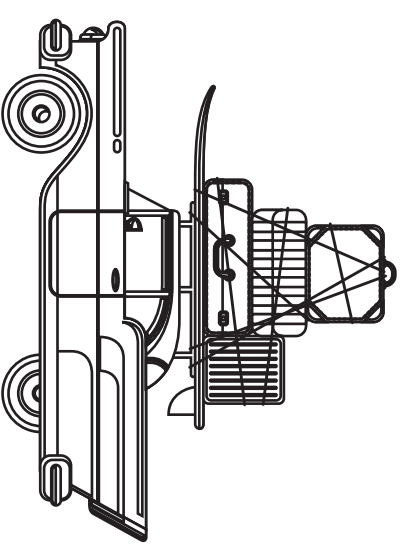

"Into your hands I commit my very life. Lord, set me  
free. You are my faithful God."  
- Psalm 31:5 (NIRV)

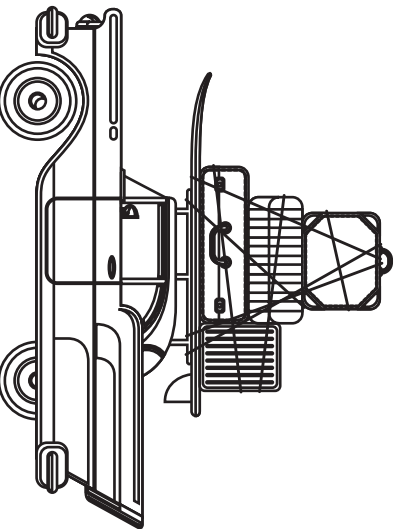

"Into your hands I commit my very life. Lord, set me  
free. You are my faithful God."  
- Psalm 31:5 (NIRV)

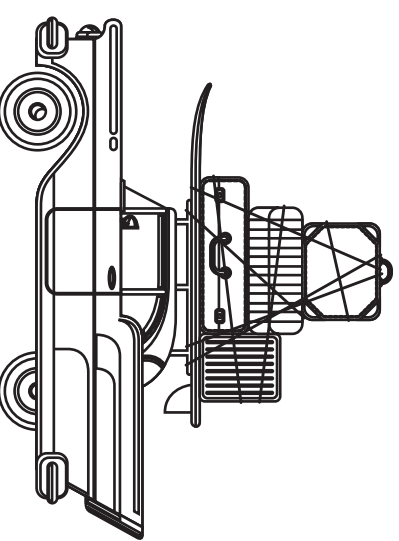

"Into your hands I commit my very life. Lord, set me  
free. You are my faithful God."  
- Psalm 31:5 (NIRV)

## CRAFT ACTIVITY

Give the kids blank paper sacks they can decorate in a way to remind themselves of the simple meal in today's lesson and God's promise to bring great things into their lives!